



# GREER MIDDLE COLLEGE CHARTER HIGH SCHOOL HOME OF THE BLAZERS

## 2010-2011 Curriculum Guide

### GENERAL INFORMATION

This guide is published to acquaint students and parents with scheduling requirements, course offerings, and course descriptions at Greer Middle College Charter High School.

The following applies to all students:

1. Students are encouraged to review this curriculum guide carefully in order to make optimum choices for their course of study in grades 9-12. Teachers and counselors can be of invaluable assistance in directing students toward courses of study that will enable them to address their interests and abilities with regard to post-secondary education and/or career choices. Please review the program of studies with your parents and make thoughtful decisions prior to registering for specific courses each year.

2. Students earn units of credit upon successful completion of approved school courses.

Students earn credit for each course if a minimum grade of **80** is achieved and the student is in attendance a minimum of 170 days. The exceptions to this are semester courses that will be offered for one half unit credits with required minimum attendance of 85 days.

3. To qualify for a state high school diploma, a student must meet minimum standards on the Exit Exam and earn unit credits distributed as follows:

### SC DIPLOMA REQUIREMENTS—GMC Diploma Requirements

**English** – 4 Units

**Math** – 4 Units **Science** – 3 Units **US History** – 1 Unit

**Economics** – ½ Unit

**Government** – ½ Unit

**Other Social Studies** – 1 Unit

**Physical Education or ROTC** – 1 Unit

**Computer Science** – 1 Unit

**Foreign Language or Occupational Specialty** – 1 Unit-- *\*\*2 Units are required to receive a diploma from GMC*

**Electives** – 7 Units--*\*\* 6 units are required at GMC*

### Exit Examination

Students must also pass the South Carolina adopted High School Assessment Program test which is administered in the spring of their second year in high school.

4. The state of South Carolina offers tuition assistance in the form of scholarships for South Carolina students. In order to receive the aid, the student must graduate from a high school in the state of South Carolina and must attend college or technical school in the state. Three different scholarships are offered. A student will be awarded the highest amount that he/she qualifies for. The criteria are as follows:

**Palmetto Fellows - (\$7000)** student must meet all 3 of the following: 1200 SAT or 27 ACT, 3.5 GPA, top 6% of class during 10th or 11th grade

**Life Scholarship - (\$5000)** student must meet 2 out of the following three: 1100 SAT or 24 ACT, 3.00 GPA, top 30% of graduating class

**Hope Scholarship - (\$2650)** one time only scholarship for students who have 3.00 GPA and a. Have no felony convictions.  
b. Have no drug or alcohol convictions.

5. In addition to the regular SC diploma, a student may qualify for the Academic Achievement Honors Award. Of the 24 units earned for the diploma, 18 must be college preparatory units, 4 may be electives, and 2 additional units must be earned in English, science, social studies, or mathematics. College preparatory units are defined as English I or above (4 units), Algebra I and above (4 units), lab sciences (3 units), social studies (3 units) chosen from US history, economics, government, world history, world geography, or western civilization, computer science (1 unit), PE (1 unit), and foreign language (2 units). In addition to these requirements, a student must receive a minimum final grade of -B|| in all coursework and achieve a score of 710 on SAT verbal/30 on ACT English OR a score of 690 on SAT Math/33 on ACT math. A student receiving a combined score of 1400 on the SAT or 31 on the ACT automatically qualifies for this award with no other criteria.

## 6. Unit Requirements for Grade Advancement

24 Units of Credit are required to obtain a SC High School Diploma.

### Grade 9

Successful completion of eighth grade

### Grade 10

5 units (must include English 1, one unit of mathematics and three other units)

### Grade 11

11 units (must include English 1 and 2, two units of mathematics, one science, and six other units)

### Grade 12

17 units (must include English 1, 2, and 3, three units of mathematics, two units of science, and nine other units)

7. The courses listed in the curriculum guide will be offered only if a sufficient number of students register for these courses. New courses may be added provided there is adequate student demand and there are adequate resources available to teach these courses.

## 8. College Admission Requirements

Students who plan to attend college should consult catalogs of colleges to assure that they are choosing the right

courses. Colleges also look at the GPA and class rank as well as College Entrance Exam scores such as the SAT or ACT for admission. Public colleges and universities in South Carolina require that applicants for freshmen admission must complete certain high school courses before being admitted. Typically, colleges expect students to take as many academic courses in English, social studies, mathematics, and science as possible.

The required courses include the following:

(These requirements apply to students graduating in 2010 or before.)

**FOUR UNITS OF ENGLISH:** At least two must have strong grammar and composition components, and

one must be in **English literature** and one must be in **American literature**.

**THREE UNITS OF MATHEMATICS:** These include **Algebra 1**, **Algebra 2**, and **Geometry**. A fourth mathematics course is strongly recommended.

**THREE UNITS OF LABORATORY SCIENCE:** Two units must be taken in two different fields selected among **biology**, **chemistry** or **physics**. The third unit may be from the same field as one of the first two units (biology, chemistry, or physics) or from advanced environmental science with laboratory or marine biology for which biology and/or chemistry is a prerequisite.

**ONE UNIT OF PHYSICAL EDUCATION OR ROTC**

**TWO UNITS OF THE SAME FOREIGN LANGUAGE** Some colleges may require three units.

**THREE UNITS OF SOCIAL SCIENCE:** One unit of **US history** is required; a half unit of **government** and a half unit of **economics** are required.

**FOUR UNITS OF ELECTIVES:** Four units of college prep electives must be taken from three different fields selected from among computer science, English, and fine arts, foreign language, laboratory science, mathematics above algebra 2, and social sciences. It is suggested that one unit be in computer science which includes programming (not just keyboarding) and one unit in fine arts (appreciation of, history or performance).

# ENGLISH

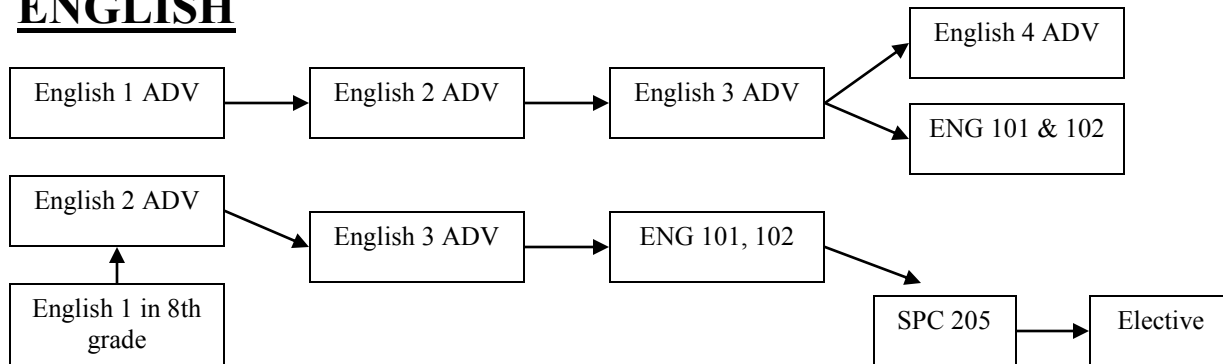

Four units of English are required for graduation. These units must be taken in sequence.

**Title:** English 1 Advanced

**Unit Credit:** 1.00

**Prerequisite:** Teacher Recommendation

For the equivalent of one semester, the student reviews grammatical concepts and learns to write effective sentences and paragraphs. The student is introduced to the three-paragraph essay. During the remainder of the year, the student concentrates on the characteristics of the following literary types: short story, novel, poetry, epic, drama, and non-fiction. Also included is a unit on mythology and the Odyssey. The student learns to appreciate the structure, language, and rhetoric of different types of literature; in addition, the student completes an in-depth study of vocabulary. This course is designed for the college-bound student who is proficient in the language arts/verbal skills.

**Title:** English 2 Advanced

**Unit Credit:** 1.00

**Prerequisite:** English 1 Adv or Teacher recommendation

This course continues the detailed study of mechanics, sentence structure, and standard usage. Students concentrate on the four basic forms of writing: narration, description, exposition, and persuasion. They are also introduced to the five paragraph essay. Students study different literary types by reading major works that include short stories, poetry, drama, non-fiction, and novels of established literary excellence. The students practice library skills needed for research and complete an extensive study of vocabulary.

**Title:** English 3 Advanced

**Unit Credit:** 1.00

**Prerequisite:** English 2 Adv or Teacher recommendation

This course combines the chronological study of American literature with advanced elements of grammar, composition, and vocabulary. The student concentrates on the multi-paragraph expository and literary essays. The student reads major American authors, investigates literary analysis and techniques, and studies recurring themes. Parallel reading, research, and oral reports provide opportunities to study and apply composition skills. A research paper is required.

**Title:** English 4 Advanced

**Unit Credit:** 1.00

**Prerequisite:** English 3 Adv or Teacher recommendation

This course combines a study of composition elements with a survey of English literature. It stresses the principles of unity, coherence, and rhetorical effectiveness in writing various organizational patterns. It focuses on correct stylistic devices in prose as exemplified by authoritative writers. The student pursues a chronological analysis of established British authors. The student is also introduced to selections of world literature of recognized merit. A research paper on a literary topic is required.



# SCIENCE

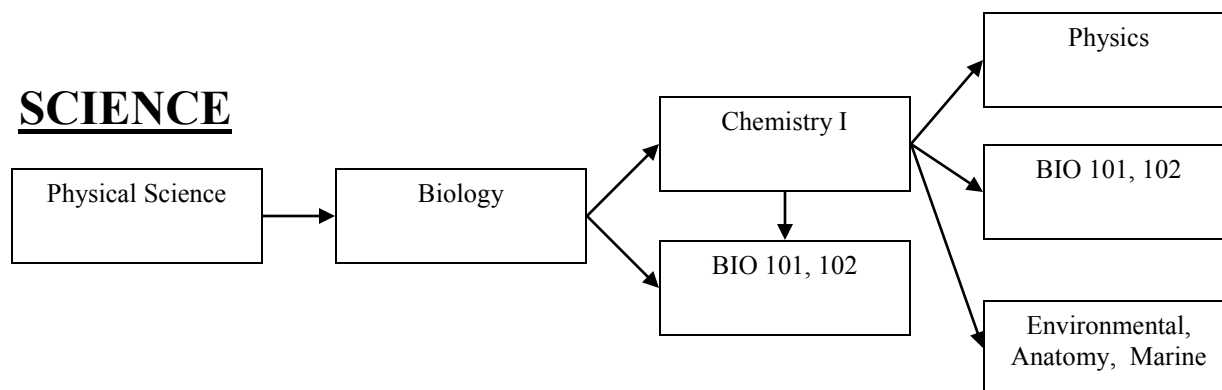

1. Three units of science are required for graduation. Two of these courses must be laboratory sciences. A unit of Physical Science is also required.
2. Science courses are sequential, but students may take several combinations as long as prerequisites are met.
3. Laboratory requirements may be met through biology, chemistry, and physics. Students and parents are reminded that public colleges and universities in South Carolina require entering students to have completed at least three laboratory science courses.

**Title:** Physical Science Advanced

**Unit credit** 1.00

**Prerequisite** Teacher recommendation

This course will serve as a foundation for students wishing to study chemistry or physics.

Concepts include measurements, matter, simple forms of energy, magnetism, light, sound, heat and electricity. This course is heavily oriented towards laboratory investigations.

**The course is not accepted as a laboratory science by South Carolina public colleges and universities.**

**Title:** Biology 1 Advanced

**Unit credit** 1.00

**Prerequisite** Teacher recommendation

This course is designed for students desiring a formal background in biology. It includes laboratory work and extensive study of specimens. Course content encompasses interrelationships of living things, levels of biological organization, human biology, social implications, biochemistry, and genetics.

**Title:** Chemistry 1 CP

**Unit credit** 1.00

**Prerequisite** 1 unit of science, concurrent Algebra 2 and/or teacher recommendation

This course is rigorous and demands a high level of abstract thinking, memorization, working with symbols, and application of knowledge to problem-solving. Student participation in laboratory activities is essential for success in this course. The course content includes organization of matter, chemical bonding, atomic structure, gases, states of matter, nomenclature, and skill development.

**Title:** Anatomy and Physiology CP

**Unit credit** 1.00

**Prerequisite** Biology 1 and Chemistry 1

This course is designed for those students interested in pursuing a career in a health field. Students will learn about human cells, tissue, organs and systems.

**Title:** Environmental Science CP

**Unit credit** 1.00

This course is designed to promote an understanding of human impact on the environment. The course includes physical and chemical properties, living systems and interrelationships. The course provides opportunities for student participation, research, field testing, experimentation, and decision-making. The SC Commission on Higher Education accepts this course as a science course for college admission with the prerequisites of Biology 1 CP and/or Chemistry 1 CP. Please note the Commission on Higher Education considers this a rigorous, upper level course and not an introductory class.

**Title:** Marine Science

**Unit Credit:** 1.0

**Grade Level:** 10-12

This course promotes an awareness of coastal and marine systems. This includes the physical and chemical properties living systems and interrelationships. This course provides opportunities for student participation in research, experimentation, dissection, field studies and decision-making. The South Carolina Commission on Higher Education accepts this course as a science course for college admission with the prerequisites of Biology 1 CP and Chemistry 1 CP.

**Title:** Physics 1

**Unit Credit:** 1.0

**Grade Level:** 10-1

This course familiarizes students with fundamental principles of physics and their applications. The course includes topics on mechanics, electricity, magnetism, thermodynamics, optics, sound and an introduction to quantum physics. Math, graphing, and problem-solving skills will comprise the basis of instruction. Advanced courses are appropriate for students who are prepared to move through the CP curriculum at an accelerated pace.

# SOCIAL STUDIES

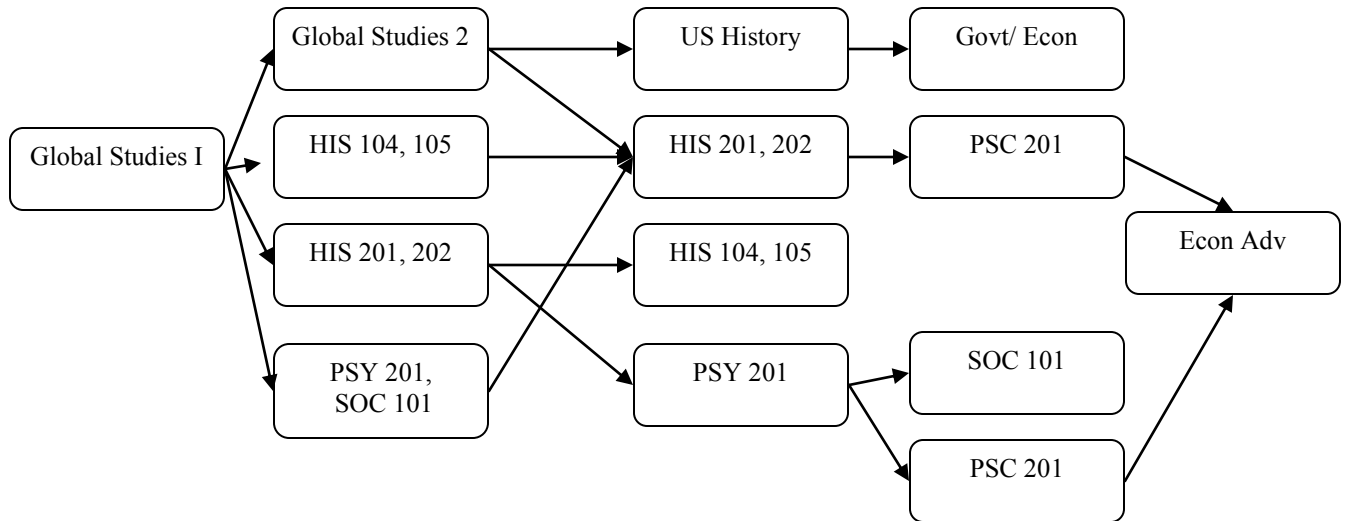

Social Studies requirements for the high school diploma include the following:  
 Government 0.5 unit, Economics 0.5 unit, US History 1 unit, Elective social studies course 1 unit

**Title:** Global Studies 1 Advanced

**Unit Credit:** 1.00

**Prerequisite:** Social Studies teacher recommendation

Global Studies 1 CP is a chronological study of the world from the development of civilization through the late Middle Ages. This course focuses on the history of early civilizations empires of the ancient world and classical civilizations and changes and developments in civilizations around the world to c. 1500. Geography skills and connections to the present are strong components of the course with relevant economic political cultural and geographical content interwoven in the curriculum. Students will apply higher order thinking skills as they consider content throughout the course.

**Title:** Global Studies 2 Advanced

**Unit Credit:** 1.00

**Prerequisite:** Social Studies teacher recommendation

Global Studies 2 is a chronological and standards-study of the world from the Renaissance to the present with an emphasis on using, refining, applying and enhancing social studies skills and concepts. These skills and concepts include the Social Studies Literacy Elements and the Knowledge and Cognitive Process Dimensions of the Revised Bloom's Taxonomy. Geography skills and connections to the present are strong components of the course.

**Title:** United States History Advanced

**Unit Credit:** 1.00

**Prerequisite:** Teacher recommendation

United States History is a survey course providing a review of the following topics: the Colonial era, the Revolutionary War, the Constitution, the rise of Nationalism and Sectionalism, the Civil War, and Reconstruction. This is followed by an in-depth study of the rise of Industrial America, Progressivism, America as a world power, the New Deal, World War II, and domestic and international policies since 1945. **U.S. History is required for graduation.**

**Title:** US Government Advanced

**Unit Credit:** 0.5

**Prerequisite:** Teacher recommendation

U.S. Government incorporates the structure, organization, and function of the American political system. Topics studied include: foundations of U.S. government, the three major branches of government, and the Constitution. Students will study the details of the political system at the national, state, and local levels. Comparisons will be made between American government and other political systems. **U.S. Government is required for graduation.**

**Title:** Economics Advanced

**Unit Credit:** 0.5

**Prerequisite:** Teacher recommendation

Economics is the study of the overall economy including both macroeconomics and microeconomics. Students will focus on topics such as money and banking, competition, supply and demand, factors of production, and consumer rights and responsibilities. **Economics is required for graduation.**

# FOREIGN LANGUAGE

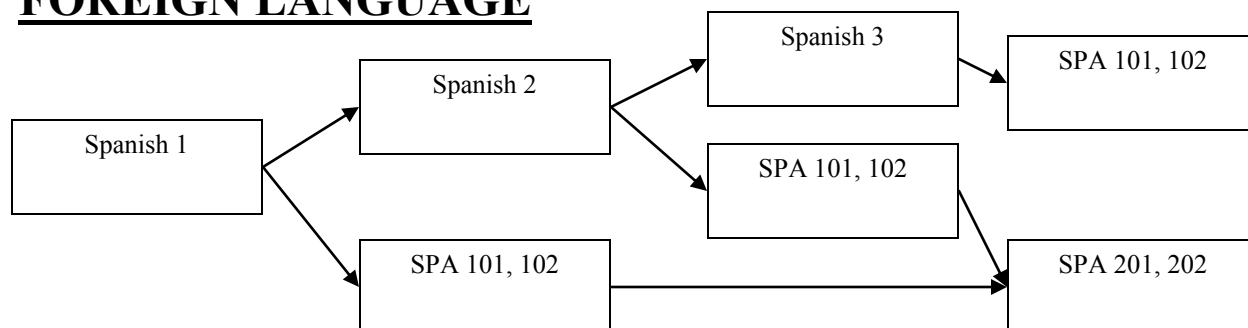

1. Students at GMC are required to earn 2 units of foreign language.
2. Public universities and colleges in South Carolina require at least two units of credit in a single foreign language for admission. Students need to check with individual colleges for specific requirements.

**Title:** Spanish 1

**Unit Credit:** 1.00

**Prerequisite:** English Teacher recommendation

This course begins to develop the skills of understanding, speaking, reading, and writing Spanish. Students will learn to pronounce and use the basic sounds and intonation patterns of the language. They will master a limited set of structural and lexical objectives to be used in common daily conversational situations. They will also gain a basic knowledge of contemporary Spanish culture as they participate in language activities to develop competence.

Reading will be limited primarily to short passages of materials covered orally and texts on culture or direct reading in Spanish.

**Title:** Spanish 2 Adv

**Unit Credit:** 1.00

**Prerequisite:** Spanish 1, Teacher recommendation

In this course students will continue to expand their knowledge of the language and culture.

The development of understanding, speaking, reading, and writing continues to be the major objective of the course. Students will expand their vocabulary as well as use new grammatical structures.

**Title:** Spanish 3 Adv

**Unit Credit:** 1.00

**Prerequisite:** Spanish 2, Teacher recommendation

In this course students will begin to expand considerably the learning of the language and culture. They will complete the study of the basic grammatical structure and will continue to develop the four skills. Reading and language activities will provide experiences in the areas of everyday needs, language careers, fine arts, and contemporary culture.

## **BUSINESS/COMPUTER**

All students must earn a unit computer science.

**Title:** Computer Apps 1

**Unit Credit:** 0.50

**Prerequisite:** None

This course is designed to introduce students to software applications that are necessary to live and work in a technological society. The applications covered include word processing, database, spreadsheet, and presentation. Other content areas may include computer hardware, terminology and concepts.

**Title:** Digital Literacy

**Unit Credit:** 0.5

**Prerequisite:** None

This course is designed to equip students with many of the needed computer skills to excel in a digital world. The student will be exposed to a broad range of computer technology from basic hardware/software to applica-

## **PHYSICAL EDUCATION**

The required PE 1 course must be conducted so that every student will meet four SC High School Student Performance Criteria for PE as mandated by the SC Department of Education.

**Title:** Physical Education 1

**Unit Credit:** 1.00

**Prerequisite:** None

Physical Education 1 provides opportunities for students to become competent and proficient in two movement forms selected from a variety of choices (selected from: net/racket, target, team, outdoor pursuits, individual, and dance). Students will also be able to design and develop a personalized physical fitness program, participate regularly in health-enhancing physical activity beyond the physical education class, and meet the gender and age group health-related physical fitness standards.

# ELECTIVES

**Title:** Accounting

**Unit Credit:** 1.0

**Grade Levels:** 10-12

This course is designed to help the student develop the skills necessary for the highly technical interaction between accounting and business, to develop an understanding of the steps of the accounting cycle as applied to several different kinds of business operations, and to develop an understanding of accounting concepts, principles and practices. Use of the computer in simulated activities gives the student an opportunity to see the advantages of technology in accounting procedures.

**Title:** Advertising

**Unit Credit:** .5

**Grade Levels:** 10-12

This course is designed to introduce the concepts of advertising, planning strategies, communication skills, and professional development. Course content includes budget development, media selection, design, and the preparation of ads for various media

**Title:** Contemporary Literature

**Unit Credit:** .5

**Grade Levels:** 10-12

The selections for this elective course, designed for the mature reader, come from today's best-seller list of various genres. Students will be exposed to a variety of authors and ideas. Oral and written response to reading selections will be used to evaluate students' understanding of the material. This course does not take the place of any required English course.

**Title:** Creative Writing

**Unit Credit:** 0.5

**Grade Levels:** 9-12

This elective course, designed for students interested in written and multimedia expression, includes a study of the various forms of poetry, fiction, nonfiction, and multimedia technology. Students will create portfolios of their own creative writing and experiment with various forms of expression. The course may culminate in the publication of a school-wide literary magazine. **This course does not take the place of any required English course.**

**Title:** Current World Events

**Unit Credit:** 0.5

This elective course enables students to examine timely topics using various current resources and media forms. Students will analyze recent events in an historical context and consider their impact on the world and their lives.

**Title:** Entrepreneurship

**Unit Credit:** .5

This course is designed to provide a general overview of the American enterprise system with special emphasis on small business ownership. An important part of the course is development of business and managerial leadership skills related to the functions of planning, organizing, staffing, directing, and controlling a small business.

**Title:** Ethnic Literature

**Unit Credit:** 0.50

**Grade Level:** 10-12

This elective course is designed for students who want to expand their knowledge of major multicultural influences in the US through the study of literature and history of various groups within our culture, especially African Americans and Asian Americans. Oral and written communication skills will be reinforced as students analyze themes from the perspectives of selected writers. This course does not take the place of any required English course.

**Title:** Film Criticism

**Unit Credit:** 1.0

**Grade Level:** 10-12

This elective course will expose students to film and cinematography. Students will become active, critical viewers of various film genre by discussing and critiquing acting, directing and production techniques. Students will be required to write various compositions related to the films. This course does not take the place of any required English course.

**Title:** Google Applications

**Unit Credit:** .5

**Grade Level:** 10-12

This course is designed to introduce the student to the many applications that Google offers. Students will be prepared for learning and working in the 21st century through communication and collaboration.

**Title:** Law Education

**Unit Credit:** 0.5

**Prerequisite:** Social Studies teacher recommendation

This elective course involves a study of different types of laws, their development, and their role in a democratic society. Emphasis will be placed on citizen rights and responsibilities, law enforcement, the judicial system, liberty, and justice. Topics include criminal law, juvenile justice, torts, consumer, family and housing law, and individual rights and responsibilities. The course focuses on the interpretation of cases and law enforcement procedures.

**Title:** Leadership

**Unit Credit:** 1.00

**Prerequisite:** Teacher recommendation

This elective course deals with developing skills in effective communication, identifying the rights and responsibilities of citizenship and learning the information necessary to organize, conduct, and participate in meetings. In addition, the characteristics of effective leadership will be studied and developed by participation in educational, civic, and social activities. Student leaders, as well as those interested in becoming leaders, are encouraged to enroll in this course

**Title:** Marketing

**Unit Credit:** .5

**Grade Level:** 10-12

This course introduces marketing concepts and examines the economic, marketing, and business fundamentals, in addition to the marketing functions of selling, promotion, and distribution. The standards listed are core standards and those standards reflecting the needs of the local business community. This is the basic course in the marketing curriculum and should be taken before the specialized courses.

**Title:** Sci Fiction Literature

**Unit Credit:** 0.50

**Grade Level:** 10-12

In this elective course, students will read short stories and novels of science fiction and fantasy. They will be exposed to a variety of authors and ideas. Oral and written response to reading selections will be used to evaluate students' understanding of the material. This course does not take the place of any required English course.

**Title:** Senior Project

**Unit Credit:** 1.00

This required course provides assistance to students in developing their senior project. Assignments and class activities will help direct the students as they develop the essential question, research, create a product and a project portfolio.

**Title:** Service Learning

**Unit Credit:** 1.0

**Grade Level:** 11-12

Service Learning is a course designed for participants to learn and develop through active participation in thoughtfully organized service experiences that meet community needs through a collaboration between the school and community. It provides students with opportunities to use newly acquired skills and knowledge in real-life situations in their own communities. The course emphasizes essential life skills such as effective communication, problem solving, goal setting, and teamwork. Students will address real-life problems and make meaningful contributions to the school and community. The emphasis will be on planning, serving, and evaluating. Time will be spent in class and at service sites.

**Title:** Southern Literature

**Unit Credit:** 1.0

**Grade Levels:** 9-12

In this elective course, students will read a variety of literature by Southern authors. Students will discuss and write the characterization, theme, and symbolism as expressed by Southern authors. Students will also relate the authors' lives to their works. Tennessee Williams, Alice Walker, William Faulkner, Pat Conroy, Flannery O'Connor, and Maya Angelou are among the authors to be studied. Emphasis will be on those aspects of literature that typify

**Title:** The Civil War

**Unit Credit:** 0.50

**Grade Level:** 10-12

This elective course examines in detail the economic, political, social, and military aspects of the Civil War. Students will gain an understanding of the short and long term consequences and legacies of the war.

**Title:** World Literature

**Unit Credit:** 1.0

**Grade Level:** 10-12

This elective course is an overview of Western literature from its beginnings with the Ancient Sumerians to the present day. World religions and art are also a part of the course study. Along with reading, much emphasis is given to improving writing skills. This course does not take the place of any required English course.

**Title:** World War II

**Unit Credit:** 0.5

This elective course examines the causes and effects of the largest war in human history. Students will discuss historical decisions of this war such as the dropping of the atomic bomb.

**Title:** Yearbook Production

**Unit Credit:** 1.0

**Grade Level:** 10-12

This is an elective course for students who have completed Journalism 2 Yearbook and who show outstanding skills in writing, design, or photography. The program includes staff organization, ad sales, and business management, feature writing, layout and design, photography, and the publication process. Students will refine skills as they produce a school yearbook. This course does not take the place of any required English course.

## DUAL CREDIT at GREENVILLE TECH

University transfer Dual Credit awards **one high school unit AP-level credit and three hours college credit**. Students who wish to enroll in dual credit courses must meet the following criteria: Be at least sophomores, have a minimum 3.0 cumulative GPA (3.5 for sophomores), score appropriate placement scores on the Compass test, exhibit maturity and independence in the classroom, and maintain good study habits. Students must apply through the guidance office. **Students who qualify to take dual credit courses must also meet the pre-requisite requirements for these courses.** For a complete list of courses refer to the Greenville Tech catalog online at: <http://www.gvltec.edu/catalog/>. Not all courses are available at all campuses. Students who do not pass a college course with **C** minimum will be required to repeat the course (at their expense) before they can re-enroll in Greenville Tech courses.

ACC101 Accounting Principles 1 383302EW 1 unit  
ACC102 Accounting Principles 2 390502EW 1 unit  
ANT 101 General Anthropology 393902EW 1 unit  
ART101 Art History 384002EW 1 unit  
ART105 Film as Art 395702EW 1 unit  
AST101 Solar System Astronomy 381402EW 1 unit  
AST102 Stellar Astronomy 395502EW 1 unit  
BIO101 Biological Science 1 381502EW 1 unit  
BIO102 Biological Science 2 381602EW 1 unit  
BIO210 Anatomy and Physiology 1 381702EW 1 unit  
BIO211 Anatomy and Physiology 2 381802EW 1 unit  
BIO225 Microbiology 395602EW 1 unit  
CHM110 College Chemistry 1 381902EW 1 unit  
CHM111 College Chemistry 2 382002EW 1 unit  
COL103 College Success Skills 380102EW 1 unit  
CPT101 Intro to Computers 385402EW 1 unit  
CPT270 Adv. Microcomputer Applications 385502EW 1 unit  
ENG101 English Composition 1 380202EW 1 unit  
ENG102 English Composition 2 380302EW 1 unit  
HIS101 Western Civilization To 1689 380402EW 1 unit  
HIS102 Western Civilization From 1689 380502EW 1 unit  
HIS105 World History  
HIS201 Amer. History: Discovery to 1877 380602EW 1 unit  
HIS202 Amer. History: 1877 to Present 380702EW 1 unit  
MAT109 College Algebra with Modeling 389983EW 1 unit  
MAT110 College Algebra 380802EW 1 unit  
MAT 111 College Trigonometry 389402EW  
MAT120 Probability and Statistics 380902EW 1 unit  
MAT130 Elementary Calculus 381002EW 1 unit  
MAT140 Analytical Geometry & Calculus 1 381102EW 1 unit  
MAT141 Analytical Geometry & Calculus 2 381202EW 1 unit  
MUS105 Music Appreciation 388702EW 1 unit  
PHI101 Introduction to Philosophy 390402EW 1 unit  
PHY201 Physics 1 382102EW 1 unit  
PHY202 Physics 2 382202EW 1 unit  
PSC201 American Government 382302EW 1 unit  
PSY201 General Psychology 382402EW 1 unit  
SOC101 Intro to Sociology 382502EW 1 unit  
SPA101 Elementary Spanish 1 385102EW 1 unit  
SPA102 Elementary Spanish 2 386902EW 1 unit  
SPC205 Public Speaking 388502EW 1 unit  
THE101 Introduction to Theater 387902EW 1 unit



## Associate in Arts Degree Planning Worksheet

<b>Required Courses</b>				<b>9.0 SHC</b>		
<b>Communications</b>	Course Taken	Grade or TR	SHC			
ENG 101 English Composition I			3			
ENG 102 English Composition II			3			
SPC 200/205/208/209 Speech Requirement			3			
<b>Humanities/Social Sciences (A minimum of one social science and one humanities)</b>				<b>12.0 SHC</b>		
<b>Humanities (Select a minimum of one courses)</b>						
ART 101,105,106,107,108,208,209,210,230,231,232	MUS 105,110					
ARA/FRE/GER/SPA (must be 102 level)	ENG 238					
HIS 101,102,104,105,106,108,109,112,115,122,201,202,220,228	THE 101,105, 240, 241					
PHI 101,105,110    ENG 238    JOU 101	IDS 201					
ENG (Literature) 201,202,205,206,208,209,213,228,230,234	REL 101,201					
<b>Social Sciences (Select a minimum of one courses)</b>						
ANT 101,202,203	PSC 201,205,215,220					
SOC 101,151,205,215, 220,235,225	ECO 210,211					
PSY 201,203,206,208,212,225	GEO 101,102,201					
<b>Mathematics/Science (A minimum of one transfer math and one transfer lab science is required).</b>				<b>7.0 SHC</b>		
MAT 103,109,110,111,120,122,130,132,140,141,211,212,215,220,230,240,242						
AST 101/102; BIO 101 or 105,102,205&206, 210,211, or 215, 216, 225; CHM 106 or 110, 111,211, 212 PHS 101,102; PHY 201,202 or 221,222						
<b>Communications/Humanities/Social Sciences - (Concentration)</b>				<b>15.0 SHC</b>		
ANT 101, 202, 203; ART 101,105,106,107,108,111,112,208,209,210,230,231,232						
ECO 210,211; English (Literature) 201,202,205,206,208,209,213,228,230,234; ENG 238						
ARA/FRE/GER/SPA (102 level)    GEO 101,102,201;    JOU 101						
HIS 101,102,104,105,106,108,109,112,115,122,201,202,220,228						
IDS 201; MUS 105,110; PHI 101,105,110; PSC 201,205,215,220; PSY 201,203,206,208,212,225						
REL 101, 201; SOC 101,151,205,215,220,225,235; THE 101,105,240,241						
<b>Other Transfer hours Required for Graduation – Choose from the following:</b>				<b>18.0 SHC</b>		
ACC 101,102    Any Math Course(s) from above						
Any Science Course(s) from above (plus) BIO 240,241; CHM 213, CHM 227; EVT 201						
Any Humanities course(s) from above (plus) MUS 101,102,103,104,110,111,112,113,114						
THE 205,259,263,270,277						
Any Social Science course(s) from above (plus) PSC 101,103,104; HUS 204						
Any Foreign Language 101,102,201,202						
ART 106,107,108,111,112,200,202,207,208,209,210,211,214,230,231,232,281,289,290,291,292;						
ARV 110,114,121,122,205,210,212,214,215,217,222,227,228,230,241,244,261,262,280; COL 103,105						
ECE 205,211,212,221,222; EDU 230; EGR 260,262,264,266,269,270,275; IDS 201, 210						
Transferred Electives: ELC foreign language. History, Literature, Political Science, Humanities, Calculus, Statistics						
Psychology, Speech, English, Music, Art						
<b>Total Minimum Hours: 61</b>						
Computer Requirement: CPT 101 or EGR 130						

\_\_\_\_\_  
(Student's Last Name)

\_\_\_\_\_  
(Student's First Name)

\_\_\_\_\_  
(Proposed Major)

\_\_\_\_\_  
(Transfer Destination)

\_\_\_\_\_  
(Datatel ID Number)

\_\_\_\_\_  
(Academic Advisor)

\_\_\_\_\_  
(Date)



Effective Fall 2010

<b>Associate in Science Degree Planning Worksheet</b>			
<i>Required Courses</i>		<b>9.0 SHC</b>	
<i>Communications</i>	Course Taken	Grade or TR	SHC
ENG 101 English Composition I			3
ENG 102 English Composition II			3
SPC 200/205/208/209 Speech Requirement			3
<i>Humanities/Social Sciences (A minimum of one social science and one humanities)</i>		<b>12.0 SHC</b>	
<i>Humanities (Select minimum of one course)</i>			
ART 101,105,106,107,108,208,209,210,230,231,232; MUS 105, 110 ARA/FRE/GER/SPA (must be 102 level) HIS 101,102,104,105,106,112,115,122,201,202,220,228 ENG (Literature) 201,202,205,206,208,209,213,228,230, 234; ENG 238	THE 101,105,240,241 IDS 201 REL 101,201 PHI 101,105,110 JOU 101		
<i>Social Sciences (Select minimum of one course)</i>			
ANT 101,202,203 ECO 210,211 GEO 101,102,201	PSC 201, 205, 215, 220 PSY 201, 203, 206,208, 212, 225 SOC 101, 205, 220, 235, 151,225		
<i>Mathematics/Science (A minimum of one transfer math and one transfer lab science is required.)</i>		<b>23.0 SHC</b>	
MAT 103,109,110,111,120,122,130,132,140,141,211,212, 215,220,230,240,242 AST 101, 102 BIO 101 or 105, 102, 205&206, 210, 211, or 215, 216, BIO 225, BIO 240 CHM 106 or CHM 110, 111, 211, 212 PHS 101, 102 PHY 201, 202 or PHY 221, 222			
<i>Other Transfer hours Required for Graduation – Choose from the following:</i>		<b>16.0 SHC</b>	
ACC 101,102; <i>Any Math Course(s) from above</i> <i>Any Science Course(s) from above (plus) BIO 241; CHM 213, CHM 227; EVT 201</i> <i>Any Humanities course(s) from above(plus) MUS 101,102,103,104,110,111,112,113,114; JOU 101</i> THE 101,105,205,240,241,259,263,270,277 <i>Any Social Science course(s) from above (plus)PSC 101,103,104; SOC 215; HUS 204</i> Any Foreign Language 101,102,201,202 ART 106,107,108,111,112,202,203,204,207,209,210,211,200,208,230,231,232,281,289,290,291,292 ARV 110,114,121,122, 205,210,212 214,215,217,222,227,228,230,241,244,261,262 COL 103,105; EDU 230; IDS 201,210 ECE 205,211,212,221,222; EGR 260,262,264,266,269,270,275 <i>Transferred Electives: ELC foreign language, history, Literature, Political Science, Humanities, calculus, statistics, Psychology, Speech, English, Music, Art</i>			
Total Minimum Hours: 60			
<b>Computer Requirement:</b> CPT 101 or EGR 130 or EGR 270			

\_\_\_\_\_  
(Student's Last Name)

\_\_\_\_\_  
(Student's First Name)

\_\_\_\_\_  
(Proposed Major)

\_\_\_\_\_  
(Transfer Destination)

\_\_\_\_\_  
(Datatel ID Number)

\_\_\_\_\_  
(Academic Advisor)

\_\_\_\_\_  
(Date)